

**TRILO**<sup>®</sup>

## SU60 Debris Loader

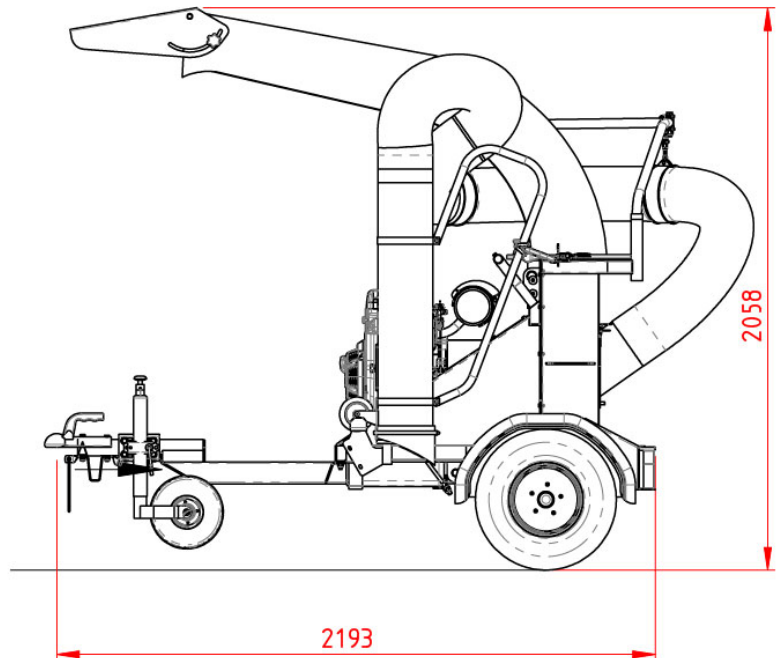
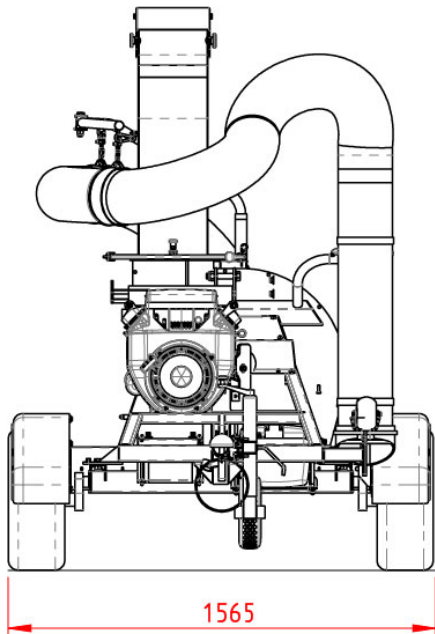

Measures are in mm

### Technical specifications

Fan diameter:	Ø 600 mm (23.6")
Number of fan blades:	4
Drive:	fan belt
Weight:	440 kg (970 lb)
Measurements (LxWxH):	2,70 x 1,63 x 2,14 m (8.85 x 5.34 x 7 ft)
Engine:	Honda GX-630 (15,5 kW; elektrik starter)
Driving speed:	80 km/h (50 mph)
Air capacity:	240 m <sup>3</sup> /min.
Noise level:	106 dB(A)
Wander hose:	Ø 250 mm with 5 meter radius
Tyres:	20.5 x 8.0-10
Transport dimensions:	480 kg (1058 lb) LxBxH: 231 x 156 x 199 cm

Under our policy of continuous improvement, we reserve the right to change specifications and design without prior notice. The illustrations do not necessarily show the standard version of the machine. Not all products are available in all countries.

Vanmac BV / Astronaut 40 / 3824MJ Amersfoort / The Netherlands / Tel: (+31) (0)33 456 45 50 / E-mail: info@trilo.com / www.trilo.com