

## T25 Hooklift vacuum units

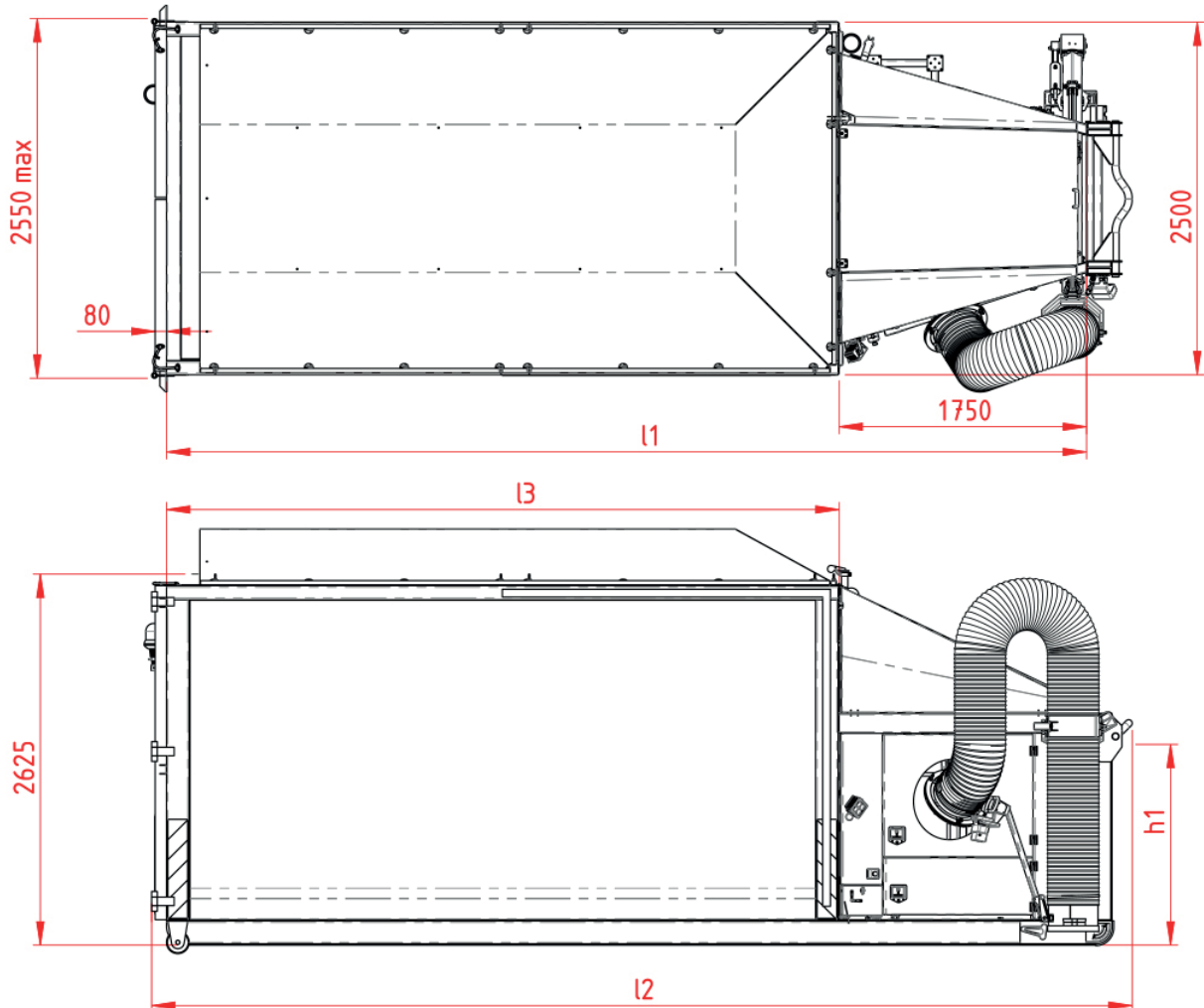

### Technical specifications

Fan diameter:	Ø 960 mm
Number of fan blades:	6
Weight:	4800 kg
Measurements (LxWxH):	6,68 x 2,51 x 2,55 m
Engine:	4-Cylinder Diesel engine
Air capacity:	385 m <sup>3</sup> /min.
Noise level:	Max. 102 dB(A) ISO 3744
Loading capacity:	25 m <sup>3</sup> (Also available with a loading capacity of: 15, 19 and 22 m <sup>3</sup> )
Suction hose:	Ø 350 mm, length 4 m

Under our policy of continuous improvement, we reserve the right to change specifications and design without prior notice. The illustrations do not necessarily show the standard version of the machine. Not all products are available in all countries.



## T25 Hooklift vacuum units

