

## S3 Compact vacuum sweepers

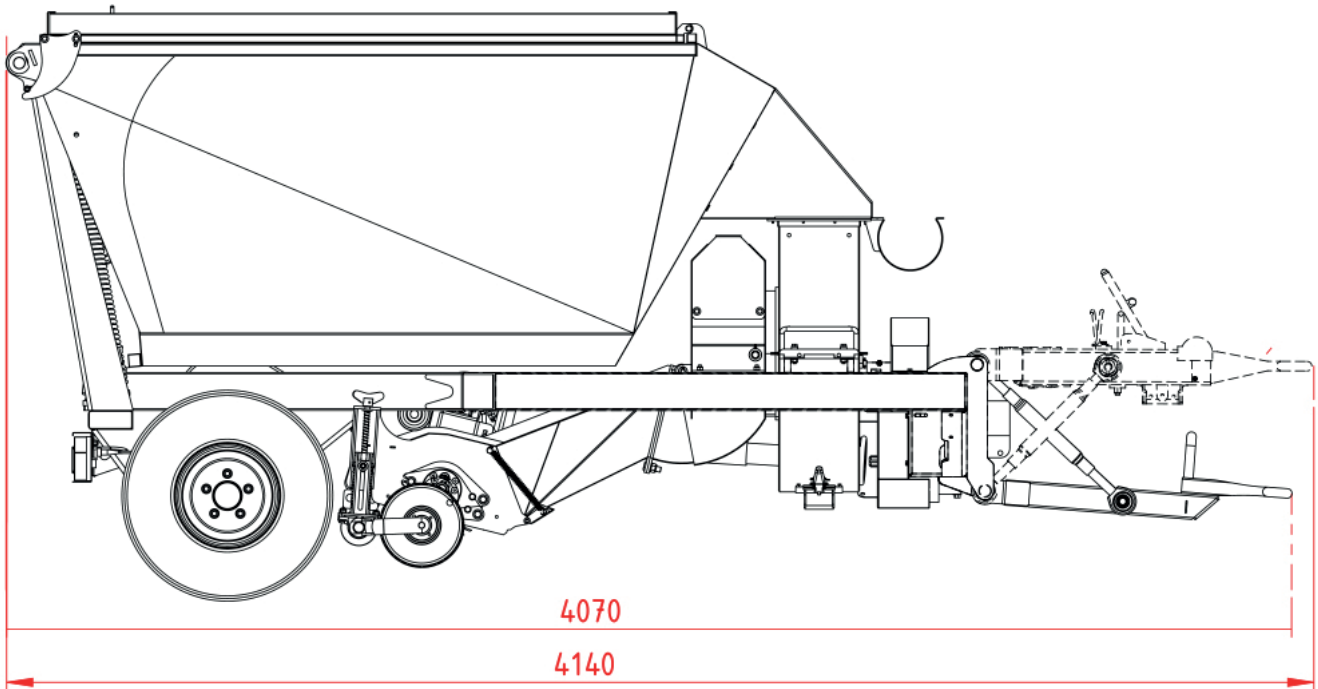

Measures are in mm

### Technical specifications

Fan diameter:	Ø 700 mm (27.5")
Number of fan blades:	4
PTO output (cut & collect):	60 - 80 hp (44 - 59 kW)
PTO output (wanderhose):	40 - 80 hp (28 - 59 KW)
PTO:	540 RPM
Drive:	Power take-off
Required hydraulics:	180 bar - 20 l/min.
Required hydraulic connections:	1 x double acting
Weight:	1240 kg (2734 lbs)
Measurements (LxWxH):	4,05 x 1,90 x 1,85 m (13 x 6.2 x 6 ft)
Air capacity:	280 m <sup>3</sup> /min.
Noise level:	90 dB(A)
Loading capacity:	3 m <sup>3</sup> (3.9 yd <sup>3</sup> )
Wander hose:	Ø 200 mm, length 5 + 1 meter (7.9", 16.4 + 3.2 ft)
Working width:	1,50 m (4.9 ft)
Tyres:	Softtrac 26.5 x 14.00-12

Under our policy of continuous improvement, we reserve the right to change specifications and design without prior notice. The illustrations do not necessarily show the standard version of the machine. Not all products are available in all countries.

## S3 Compact vacuum sweepers

