



SU40 Debris Loader

Mounted on trailer chassis for clearing leaves and debris



TRILO SU40 debris loaders can handle any leaf or debris challenges you have

TRILO SU40 debris loaders are ideal for loading trucks or trailers with large amounts of debris or leaves. Because of the special shape of the square discharge spout and a fan specially designed for this configuration, a strong airflow is created. Therefore TRILO SU truck loaders, have a tremendous suction power that makes clearing large quantities of leaves and debris an easy job to do. This optimum design also requires less power and saves you fuel.

The powerful and tough manganese steel impeller blades shred debris to a small mulch. The mulched debris will evenly spread and take up less space. This means you can load more and work longer by saving time on regular, unnecessary, unloading journeys. The TRILO SU40 debris loaders are powered by extremely reliable Honda GXV 340 engines that offer quiet operation and low fuel consumption. The impeller and blower housing can easily be serviced through the rear access panel. The housing is lined with manganese steel exchangeable wear

plates. The fan housing of a TRILO SU40 debris loader is easy to clean with a garden hose and excess water is simply drained by using a drain plug in the bottom of the fan housing.

The SU40 is standard equipped with suction hose with a radius of 5 metres and a diameter of 200 mm. The intake hose also includes a robust metal end piece with a hand grip that is designed for increased leverage and easy maneuverability. The castor wheel on which the pipe rests when you are working carries the weight for you and makes the job much easier. While working, the intake hose is also supported by a pivoting boom and when you are finished, you can tuck the intake hose safely away in a bracket. The adjustable reverse exhaust spout can be turned 360 degrees and can be adjusted to any desired angle, so you can blow material into a vehicle's bin at the most inaccessible areas. TRILO machines are exceptionally well engineered and will easily serve you for many years to come. Every machine is sold with premium service and warranty.



Discharge spout can be turned 360 degrees.



Adjustable end flap.



Easy access to the impeller for cleaning.



Safety sensor on fan housing shuts off engine during maintenance work.



80 km/h road prove Galvanized Torque shaft suspension.

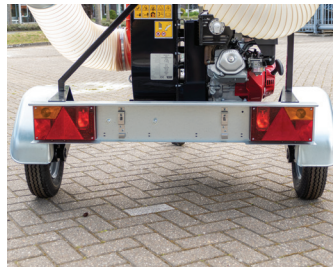

Street lights and number plate holder.



Easy to clean with a garden hose excess Water is drained by plug.



Smart designed Square stack for superior airflow.



Extremely reliable Honda petrol Honda GXV 340 engine.



Castor wheel supports the weight while operating the suction hose.



Sturdy end pipe with grip for increased leverage and easy maneuverability.



The suction hose with a 5 m radius is supported by a pivoting boom.

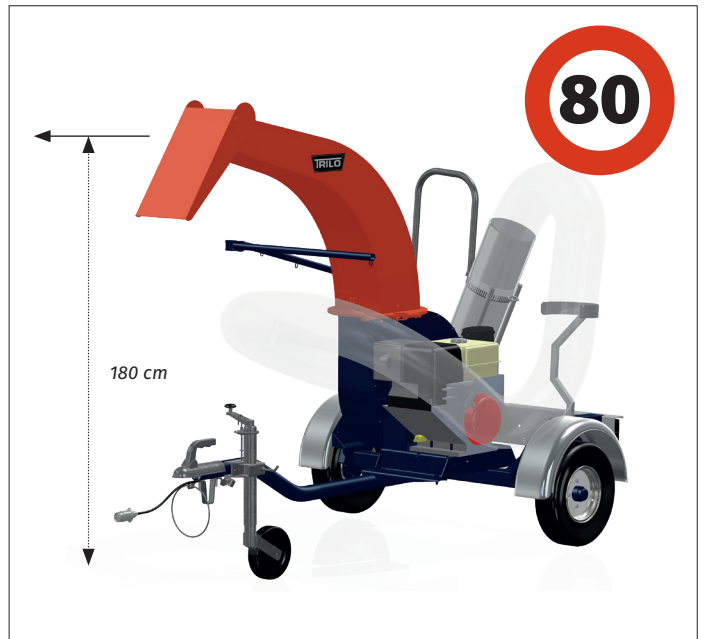

TRILO machines are exceptionally well engineered and will easily serve you for many years to come. Every machine is sold with premium service and warranty.

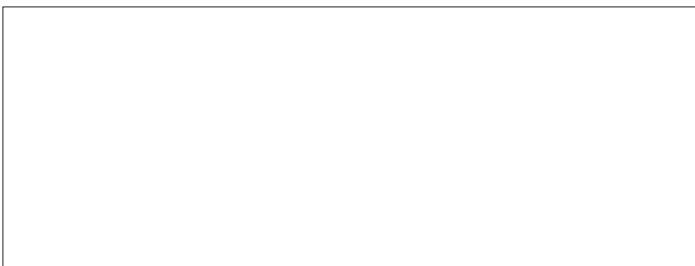

Your official TRILO dealer